

## **FMS TRAINING SET**

**Flexible  
Manufacturing  
System  
Training Set**

# FLEXIBLE MANUFACTURING SYSTEM



ALUMINUM WORKPIECES (100 sets)



PLASTIC WORKPIECES (100 sets)

## ADVANTAGES

Unfortunately, the production of such a training set, which is produced and sold by foreign companies, has not been made in our country until today. It has some advantages over competing brands in terms of flexibility.

The equipment used on the set is latest tech product and aims to teach the users the latest technological developments as well as the current automation technology.

S71200 series 1212C CPU is used in each module. This design feature allows each module to be used independently or integrated with other stations. KTP400 series screen will be used in each module and optionally KTP700 or higher can be used.

The flexible manufacturing system can be purchased as a whole or in parts, depending on the budget. This makes different purchasing preferences valid. When the stations are purchased piece by piece, the set can be completed in the future according to the budget.

## PRODUCT QUALITY

- All pneumatic elements (including unions and tubes) are SMC brand (made in Japan).
- All automation elements are Siemens brand (Made in Germany).
- Brands such as Siemens, Schneider, Phoenix Contact, Pilz are used in all electrical control panel equipments.
- The electric actuators and drivers used in the 5th Station are SMC brand (Made in Japan).
- Step motors and drivers, except for the 5th station, were produced in the name of MODULE by a company that produces for many brands in the world.
- Except for the chassis group, all of the aluminum materials are 6060 or 7075 series and colored anodized coating process has been applied.
- Siemens SIMATIC HMI comfort panel is used on the main control panel controlled by the instructor. This screen has a special structure and also allows data to be saved.
- Valve terminals are SMC brand and are new generation smart valve terminals suitable for Industry 4.0.

## WORKPIECE COMPONENTS

Cover / Bolt / Shaft / Body / Bearing / Bushing O-ring

## DESCRIPTION

Technological developments have led to an increase in the features expected from the employees and the diversity of the features. For this purpose, we are proud of breaking new ground with our expert employees and nearly 30 years of corporate experience.

With the flexible manufacturing system, a tiny model of a factory has been made. It has been meticulously designed by our design team and produced with domestic facilities.

The set consists of 8 modules, 1 of which is optional.

## WHY FLEXIBLE MANUFACTURING SYSTEM?

- 4 different workpieces can be produced, each consisting of approximately 7 parts.
- Each station can be used independently of each other.
- It can be purchased as a complete option, as well as allowing options such as single, double, triple, quadruple





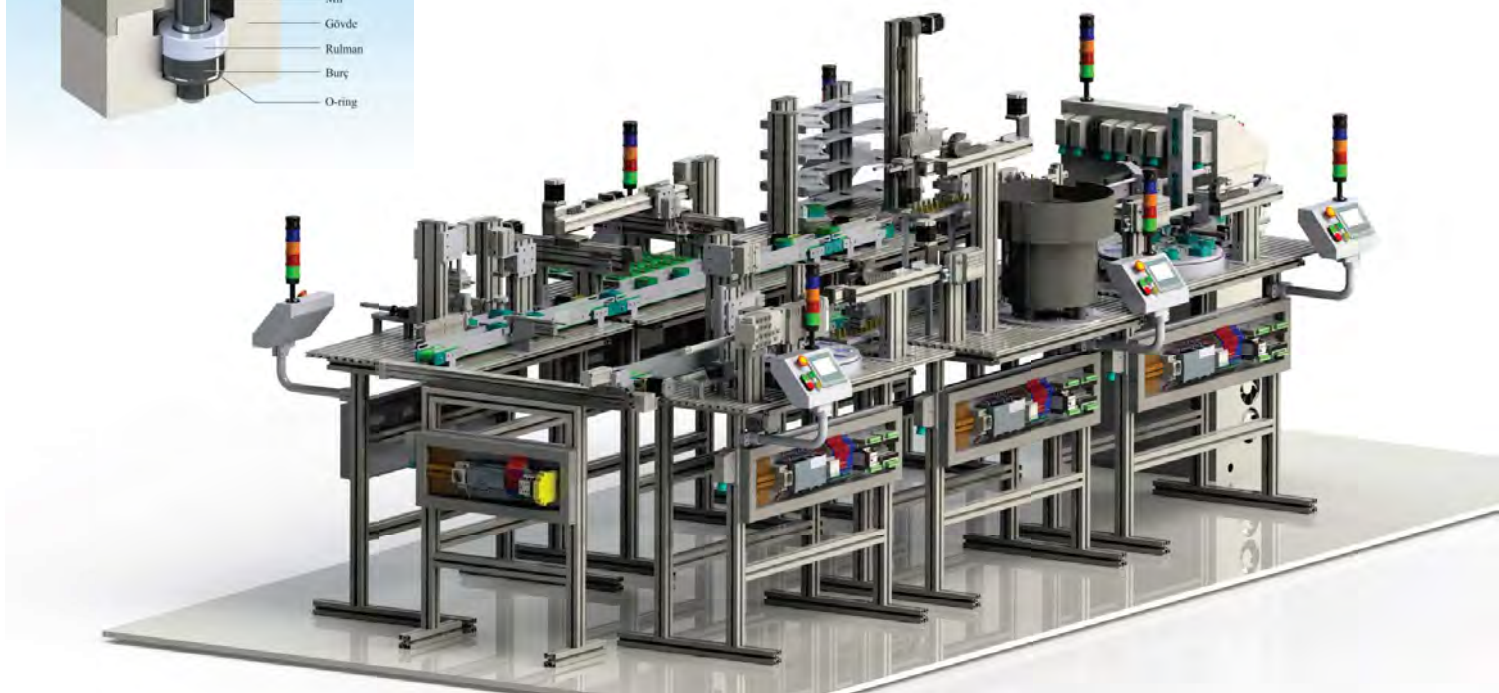

- ↘ Separation of different types of workpieces
- ↘ **Conveyor application**
- ↘ Rotary table application
- ↘ **Transfer application with rodless cylinder**
- ↘ Using the vibration bowl feeder
- ↘ **Positioning of the parts coming from the vibration bowl feeder in a certain position**
- ↘ Measure control application with 4-20 mA analog measuring sensor
- ↘ **Sorting out the workpieces with the vision sensor**
- ↘ Sealing test applications with 0-10V analog pressure measurement process
- ↘ **Sorting products by material type**
- ↘ Sequential assembly applications according to the determined scenario
- ↘ **Use of inductive sensors**
- ↘ Optical sensor application
- ↘ **Vacuum sensor application**
- ↘ Pressure sensor with digital display application

- ↘ **Analog sensor application**
- ↘ Loadcell application
- ↘ **Linear and rotary actuator applications**
- ↘ Piece holding and handling application with vacuum
- ↘ **Piece holding and handling with the gripper**
- ↘ Single axis stepper motor application
- ↘ **Double axis stepper motor application**
- ↘ Cartesian robot application
- ↘ **Assembly conformity check**
- ↘ Tightness and pressure test
- ↘ **Force test (bearing fitting)**
- ↘ Analog and digital PLC applications
- ↘ **Servo-pneumatic applications**
- ↘ Material transfer between lines (optional)
- ↘ **Automatic screwing (optional)**
- ↘ Industrial robot application (optional)
- ↘ **Packaging (optional)**

**DESCRIPTION**

With the use of inductive and capacitive sensors, a distinction is made according to the type of material. Parts made of plastic and aluminum are placed on the rotary table by linear transfer or pushed onto the conveyor.

O-ring (gasket) is placed on workpieces made of aluminum.

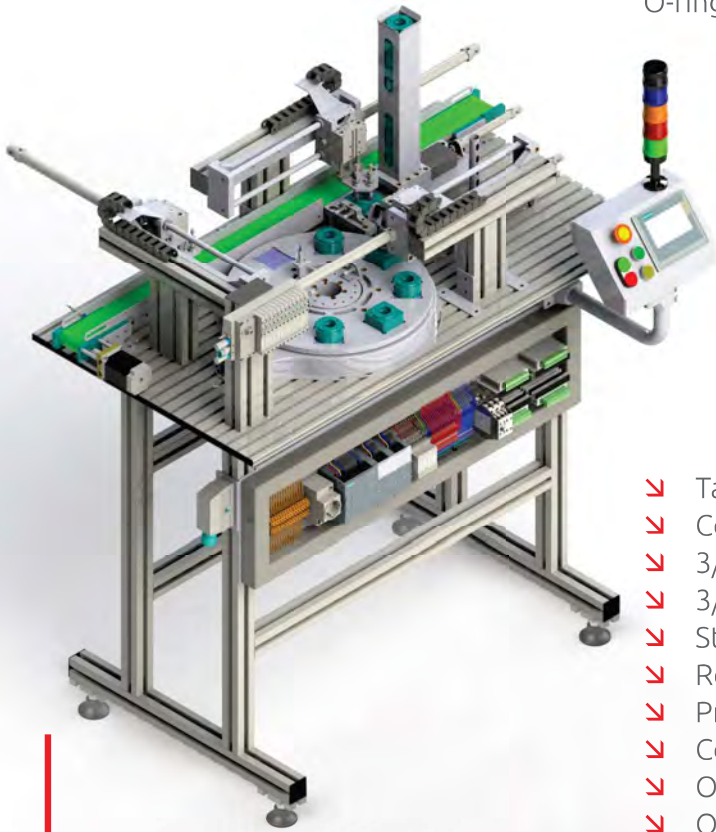

- ↘ Table dimensions: 900 (H) x 600 (W) x 1200 (L)
- ↘ Conditioner (filter and regulator)
- ↘ 3/2 way Single Solenoid valve
- ↘ 3/2 way Manual ON-OFF valve
- ↘ Step motor (2 pcs)
- ↘ Rotary table
- ↘ Pneumatic linear workpieces (8 pcs)
- ↘ Color sensor (optional)
- ↘ On-cylinder magnetic sensor (17 pcs)
- ↘ On-cylinder dimmer (16 pcs)
- ↘ Inductive + optical sensor (14 pcs)
- ↘ 1-5V pressure sensor with digital display
- ↘ Gripper
- ↘ Vacuum switch (2 pcs)
- ↘ Vacuum generator (2 pcs)
- ↘ Vacuum pad and vacuum elements (2 sets)
- ↘ EX 600 valve terminal
- ↘ Pneumatic directional control valve (12 pcs)
- ↘ Profinet communication protocol
- ↘ Conveyor
- ↘ S7 1200 1212C CPU DC/DC/DC
- ↘ SM12-23DI 8 x 24VDC/DO 8 x 24VDC modules
- ↘ KTP400 basic HMI
- ↘ Illuminated Pushbutton (2 pcs)
- ↘ Twin button
- ↘ Emergency stop button
- ↘ Light tower
- ↘ Operator panel
- ↘ Phoenix Slim relay (8 pcs)
- ↘ Schneider electric contactor
- ↘ Single row terminal block (12 pcs.)
- ↘ Double-deck terminal block (8 pcs)

**DESCRIPTION**

In the second station, a vibration bowl feeder, which we could not see in similar training sets, was used.

The products that come in order with automatic feeding from the vibration bowl feeder are measured separately with the analog measuring sensor. With the measurement, it is understood in which workpiece the element will be used.

According to the measurement result, the measured parts are arranged in the relevant magazine in a certain position and in a certain order.

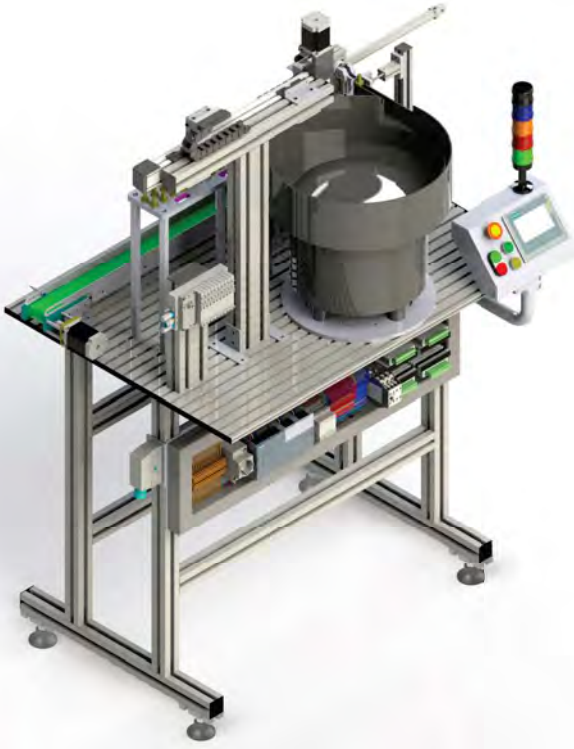

- ↘ Table dimensions: 900 (H) x 600 (W) x 1000(L)
- ↘ Conditioner (filter and regulator)
- ↘ 3/2 way Single Solenoid valve
- ↘ 3/2 way Manual ON-OFF valve
- ↘ Step motor (2 pcs)
- ↘ Pneumatic linear workpieces (5 pcs)
- ↘ Pneumatic rotary workpiece
- ↘ Gripper (2 pcs)
- ↘ On-cylinder magnetic sensor (14 pcs)
- ↘ On-cylinder dimmer (10 pcs)
- ↘ Magazine table
- ↘ Vibration bowl feeder
- ↘ Inductive + optical sensor (10 pcs)
- ↘ 1-5V pressure sensor with digital display
- ↘ EX 600 valve terminal
- ↘ Pneumatic directional control valve (8 pcs)
- ↘ Profinet communication protocol
- ↘ Conveyor
- ↘ S7 1200 1212C CPU DC/DC/DC
- ↘ SM12-23DI 8 x 24VDC/DO 8 x 24VDC module
- ↘ KTP400 basic HMI
- ↘ Illuminated Pushbutton (2 pcs)
- ↘ Twin button
- ↘ Emergency stop button
- ↘ Light tower
- ↘ Operator panel
- ↘ Phoenix Slim relay (8 pcs)
- ↘ Schneider electric contactor
- ↘ Single row terminal block (12 pcs.)
- ↘ Double-deck terminal block (8 pcs)
- ↘ Triple-deck terminal block (16 pcs)
- ↘ Rail mount power socket
- ↘ 16 pin connector

**DESCRIPTION**

At the station, the shape of the part is determined with the vision sensor and grouping is done in the correct order according to the determined part shape.

Leak test is performed only on workpieces that are square and made of aluminum material.

The leak test determines whether the assembly process is done correctly. Problematic products are separated.



- ✚ Table dimensions: 900 (H) x 600 (W) x 1200(L)
- ✚ Conditioner (filter and regulator)
- ✚ 3/2 way Single Solenoid valve
- ✚ 3/2 way Manual ON-OFF valve
- ✚ Step motor (3 pcs)
- ✚ Rotary table
- ✚ Magazine table
- ✚ Pneumatic linear workpieces (7 pcs)
- ✚ Rotary cylinder workpiece
- ✚ Linear axis
- ✚ Vision sensor
- ✚ On-cylinder magnetic sensor (20 pcs)
- ✚ On-cylinder dimmer (16 pcs)
- ✚ Inductive + optical sensor (20 pcs)
- ✚ 1-5V pressure sensor with digital display (2 pcs)
- ✚ Gripper (4 pcs)
- ✚ EX 600 valve terminal
- ✚ Pneumatic directional control valve (13 pcs)
- ✚ Profinet communication protocol
- ✚ Conveyor
- ✚ S7 1200 1212C CPU DC/DC/DC
- ✚ SM12-23DI 8 x 24VDC/DO 8 x 24VDC module
- ✚ KTP400 basic HMI
- ✚ Illuminated Pushbutton (2 pcs)
- ✚ Twin button
- ✚ Emergency stop button
- ✚ Light tower
- ✚ Operator panel
- ✚ Phoenix Slim relay (8 pcs)
- ✚ Schneider electric contactor
- ✚ Single row terminal block (12 pcs.)
- ✚ Double-deck terminal block (8 pcs)
- ✚ Triple-deck terminal block (16 pcs)
- ✚ Rail mount power socket
- ✚ 16 pin connector



**DESCRIPTION**

Thanks to the rotating system, bearings are placed inside the body without making any part separation at the station.

After the correct placement is done, the bearing is driven with the determined force. The driving force can be adjusted with the help of a proportional regulator.

If the required force is not generated, the driving operation will not take place and the system will stop working and give an alarm.

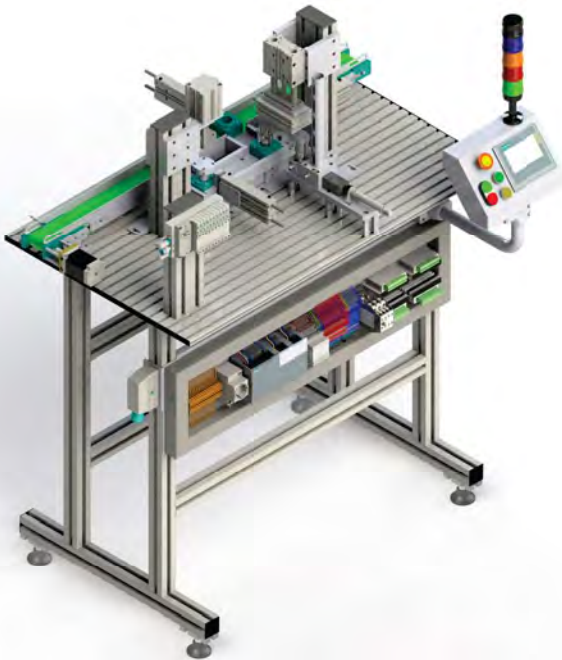

- ↘ Table dimensions: 900 (H) x 600 (W) x 1000(L)
- ↘ Conditioner (filter and regulator)
- ↘ 3/2 way Single Solenoid valve
- ↘ 3/2 way Manual ON-OFF valve
- ↘ Step motor
- ↘ Pneumatic linear workpieces (6 pcs)
- ↘ Rotary cylinder workpiece
- ↘ On-cylinder magnetic sensor (14 pcs)
- ↘ On-cylinder dimmer (12 pcs)
- ↘ Inductive + optical sensor (7 pcs)
- ↘ 1-5V pressure sensor with digital display
- ↘ 0-10V load cell analog amplifier
- ↘ 0-10V analog regulator
- ↘ Gripper (2 pcs)
- ↘ EX 600 smart valve terminal
- ↘ Pneumatic directional control valve (7 pcs)
- ↘ Profinet communication protocol
- ↘ Conveyor
- ↘ S7 1200 1212C CPU DC/DC/DC
- ↘ SM12-23DI 8 x 24VDC/DO 8 x 24VDC module
- ↘ KTP400 basic HMI
- ↘ Illuminated Pushbutton (2 pcs)
- ↘ Twin button
- ↘ Emergency stop button
- ↘ Light tower
- ↘ Operator panel
- ↘ Phoenix Slim relay (8 pcs)
- ↘ Schneider electric contactor
- ↘ Single row terminal block (12 pcs.)
- ↘ Double-deck terminal block (8 pcs)
- ↘ Triple-deck terminal block (16 pcs)
- ↘ Rail mount power socket
- ↘ 16 pin connector

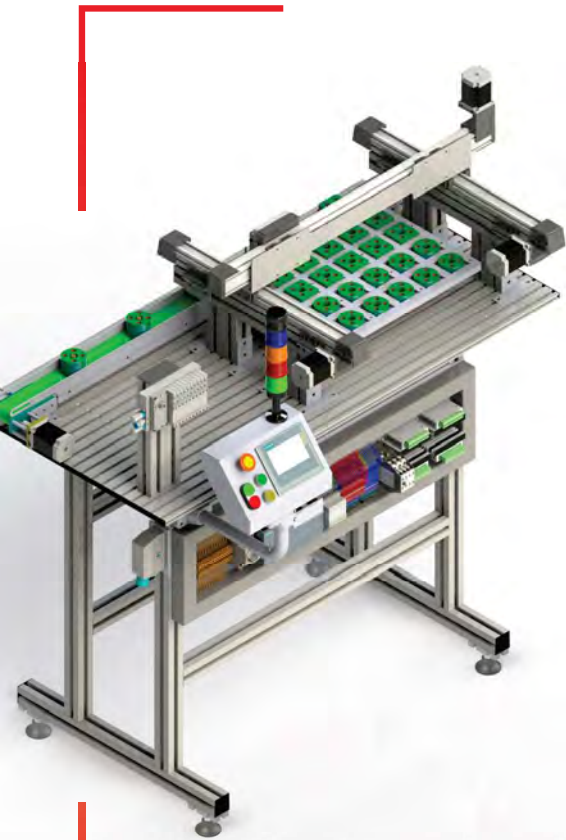

### DESCRIPTION

At the station, workpieces with different characteristics are separated by sensors according to material type and shape. By using 4 axes with step motor control, it is ensured that the right cover is attached to the right workpiece. Transfer (transport) process takes place with vacuum.

Siemens S7 1200 1212C CPU was used on the training set. Thanks to the expansion modules, the number of inputs and outputs has been increased. The control and supervision of the process is provided through the KTP 400 screen. Optionally, it can be made more functional by adding other kits to the set.

3 pcs. step motor controlled axes are SMC (Japanese made), valve terminal is SMC Ex600 model. All pneumatic elements are SMC (Japanese) branded. Automation components are Siemens (German) brand.

- ↘ Table dimensions: 900 (H) x 600 (W) x 1200(L)
- ↘ Conditioner (filter and regulator)
- ↘ 3/2 way Single Solenoid valve
- ↘ 3/2 way Manual ON-OFF valve
- ↘ Step motor (3 pcs)
- ↘ Linear axis (2 pcs)
- ↘ Pneumatic linear workpieces
- ↘ Magazine table
- ↘ On-cylinder magnetic sensor (2 pcs)
- ↘ On-cylinder dimmer (2 pcs)
- ↘ Inductive + optical sensor (15 pcs)
- ↘ 1-5V pressure sensor with digital display
- ↘ Vacuum switch
- ↘ Vacuum generator
- ↘ Vacuum pad and vacuum elements set
- ↘ EX 600 valve terminal
- ↘ Pneumatic directional control valve (2 pcs)
- ↘ Profinet communication protocol
- ↘ Conveyor
- ↘ S7 1200 1212C CPU DC/DC/DC
- ↘ SM12-23DI 8 x 24VDC/DO 8 x 24VDC module
- ↘ KTP400 basic HMI
- ↘ Illuminated Pushbutton (2 pcs)
- ↘ Twin button
- ↘ Emergency stop button
- ↘ Light tower
- ↘ Operator panel
- ↘ Phoenix Slim relay (8 pcs)
- ↘ Schneider electric contactor
- ↘ Single row terminal block (12 pcs.)
- ↘ Double-deck terminal block (8 pcs)
- ↘ Triple-deck terminal block (16 pcs)
- ↘ Rail mount power socket
- ↘ 16 pin connector
- ↘ Red main supply hose
- ↘ Gray flexible corrugated hose
- ↘ Yellow vacuum hose
- ↘ 25 pcs. workpiece (overprinted)



## DESCRIPTION

It is ensured that the workpieces grouped in the station are placed on the correct shelf. Two separate mechanisms can be used for the placement process. Mechanisms may vary on demand.

The placement process can be done by manual feeding, or optionally, there is a cartesian robot or industrial robot alternative.

An additional station can be optionally added to the flexible manufacturing systems training set. At the end of the placement process in the 6th station, there may be a packing station.

- ✘ Table dimensions: 900 (H) x 600 (W) x 1000(L)
- ✘ Conditioner (filter and regulator)
- ✘ 3/2 way Single Solenoid valve
- ✘ 3/2 way Manual ON-OFF valve
- ✘ Step motor (3 pcs)
- ✘ Linear axis
- ✘ Mechanical angular rotary axis system
- ✘ Industrial robot (optional)
- ✘ Pneumatic linear workpieces
- ✘ Magazine table (4 pcs)
- ✘ On-cylinder magnetic sensor (2 pcs)
- ✘ On-cylinder dimmer (2 pcs)
- ✘ Inductive + optical sensor (8 pcs)
- ✘ 1-5V pressure sensor with digital display
- ✘ Gripper
- ✘ EX 600 valve terminal
- ✘ Pneumatic directional control valve (2 pcs)
- ✘ Profinet communication protocol
- ✘ Conveyor
- ✘ S7 1200 1212C CPU DC/DC/DC
- ✘ SM12-23DI 8 x 24VDC/DO 8 x 24VDC module
- ✘ KTP400 basic HMI
- ✘ Illuminated Pushbutton (2 pcs)
- ✘ Twin button
- ✘ Emergency stop button
- ✘ Light tower
- ✘ Operator panel
- ✘ Phoenix Slim relay (8 pcs)
- ✘ Schneider electric contactor
- ✘ Single row terminal block (12 pcs.)
- ✘ Double-deck terminal block (8 pcs)
- ✘ Triple-deck terminal block (16 pcs)
- ✘ Rail mount power socket
- ✘ 16 pin connector



**DESCRIPTION**

The transfer station is offered as an optional feature. The FMSADO-FC Flexible Manufacturing Systems Training set can be placed linearly or in a "U" shape to save space.

U-shaped placing is used in the transfer station to transfer materials from one line to the other. This will need to be done manually when the transfer station is not in use.

If the stations, which are prepared as training tables, are placed linearly, there is no need to use a transfer station.



- ✚ Table dimensions: 900 (H) x 300 (W) x 1040(L)
- ✚ Conditioner (filter and regulator)
- ✚ 3/2 way Single Solenoid valve
- ✚ 3/2 way Manual ON-OFF valve
- ✚ Pneumatic linear workpieces
- ✚ Rodless cylinder
- ✚ On-cylinder magnetic sensor (4 pcs)
- ✚ On-cylinder dimmer (4 pcs)
- ✚ Optical sensor
- ✚ 1-5V pressure sensor with digital display
- ✚ EX 260 valve terminal
- ✚ Pneumatic directional control valve (2 pcs)
- ✚ LOGO 12/24RCE smart relay
- ✚ LOGO DM8 12/24R module
- ✚ Twin button
- ✚ Emergency stop button
- ✚ Light tower
- ✚ Phoenix Slim relay (8 pcs)
- ✚ Schneider electric contactor
- ✚ Single row terminal block (12 pcs.)
- ✚ Double-deck terminal block (8 pcs)
- ✚ Triple-deck terminal block (8 pcs)
- ✚ Rail mount power socket
- ✚ 16 pin connector
- ✚ Pilz PNOZS2.824VDC safety relay
- ✚ Red main supply hose
- ✚ Gray flexible corrugated hose
- ✚ Yellow vacuum hose

### DESCRIPTION

When the whole training set is purchased, all stations in the set are controlled via the main control panel.

Thanks to the control system, the instructor can follow the work done in each module. He can interfere when necessary. In emergency situations, he can interfere in the operation of the system with the help of PLC on its control panel. Also, all stations can be stopped independently.

A larger screen is used in the control panel. This screen has a feature-rich structure and also allows data to be saved. Pneumatic circuit diagrams of all stations, electrical circuit diagrams, application examples, control and command software, user manuals of the circuit elements and devices used on the set, and all similar documents and software are included.

When the training set is purchased as a module, there is a PLC control unit and a command unit on each module that allows individual use. All kinds of applications can be done easily without the need for the main control panel.

### Control Panel

- Panel dimensions: 180mm(H) x 600mm(W) x 300mm(D)
- 1.70 mm plate thickness
- Electrically insulated, oven-drying
- Fully touch-sensitive Siemens TP Comfort HMI Panel enabling functional use
- 2 warning lamps
- 17 signal lamps
- 1 keyed emergency stop button
- 1 button
- In addition, 8 power connectors and 2 8-wire scales are used behind the control panel, providing fast connection.

### Control Board

- Board dimensions: 1.140 mm (H), 600 mm (W), 280 mm (D)
- 1 x 30 mA residual current relay
- Siemens S-1214FC DC/DC/DC type safety PLC is used in the control panel for safety purposes.
- 1 SM1221 8DI/8DO digital input-output module is used.
- 2 SM1226F-DQ DC modules are used.
- A total of 2 C type automat fuses were used, of which 10 are 2A, 4 are 4A and 8 are 6A.
- For power demand, OMRON brand 3 x 120W and 6 x 240W Rail mount Power supplies giving 24 volts output are used.
- 10 Schneider 8 pin 24V DC relays are used.
- A total of 75 rail mount terminal blocks, 21 single row, 40 double row, 14 triple row, were used.
- 4 filtered ventilation fans to prevent dust formation in the panel and to regulate the air flow.
- 1 piece of rail mount power socket
- 1 electrical switch on the side panel
- There is lighting inside the control panel and it is activated automatically when the cover is opened.



### FOLLOW US



#### Modül Modern Eğitim Teknolojileri A.Ş

+90 236 304 45 75  
+90 236 304 45 75  
info@metdidactic.com.tr

Muradiye Mah 8. Sk.  
No: 21/I Yunusemre  
Manisa / Türkiye

[www.metdidactic.com.tr](http://www.metdidactic.com.tr)





With its didactic experience and the vision of "on-the-job training" MET I Didactic creates content develops tools and manages the process by using technology for the trainings it offers specific to the sector and the company



met | Didactic

## OCCUPATIONAL AND TECHNICAL TRAININGS

### Machinery-Mechanical Trainings

- Basic Hydraulics
- Advanced Hydraulics
- Hydraulic Maintenance and Troubleshooting
- Project Based Hydraulics
- Construction Machinery Hydraulics (Mobile Hydraulics)
- Basic Pneumatics, Electropneumatics
- Advanced Pneumatics and Electropneumatics
- Pneumatic Maintenance and Troubleshooting
- Project Based Pneumatics
- Remote Monitoring and Predictive Maintenance Methods According to Industry 4.0
- Machinery Mechanical Maintenance and Repair
- Bearing Selection, Assembly and Disassembly Applications
- Measurement and Control Information
- Cooling Systems and Coolers

### Machinery-Mechanical Trainings

- Basic PLC
- Advanced PLC and Operator Panel
- Basic S7-300 & S7-400 PLC
- Advanced S7-300 & S7-400 PLC
- Servo, Stepper Motors and Drivers
- Industrial Sensors and Sensor Techniques
- Electrical-Electronic Maintenance and Troubleshooting

## OCCUPATIONAL AND TECHNICAL SEMINARS

- Industrial Electronics
- Energy Efficiency in Industrial Systems
- Energy Efficiency in Industrial Systems
- Compressed Air Saving in Pneumatic Systems
- Motion Transmission Systems
- Pulley, Clutch, Gears etc.)
- Proportional and Servo Valves
- Making Hydraulic Fittings and Hose Measurements
- Steam Systems
- Vacuum Applications
- Industrial Lubricants and Lubrication
- Cartridge (Logic) Valves
- Selection and Installation of Sealing Elements
- Hydraulic Oils
- Reading and Interpreting Hydraulic Circuit Diagrams
- Hydraulic Circuit Design and Project Creation Techniques
- Reading and Interpreting Pneumatic Circuit Diagrams

### Welding Trainings

- Electric Arc Welding
- Oxygen Welding
- Gas Metal Arc Welding

